

**BARRIER CURB DETAIL**  
COMMERCIAL/ INDUSTRIAL/  
MULTI-FAMILY

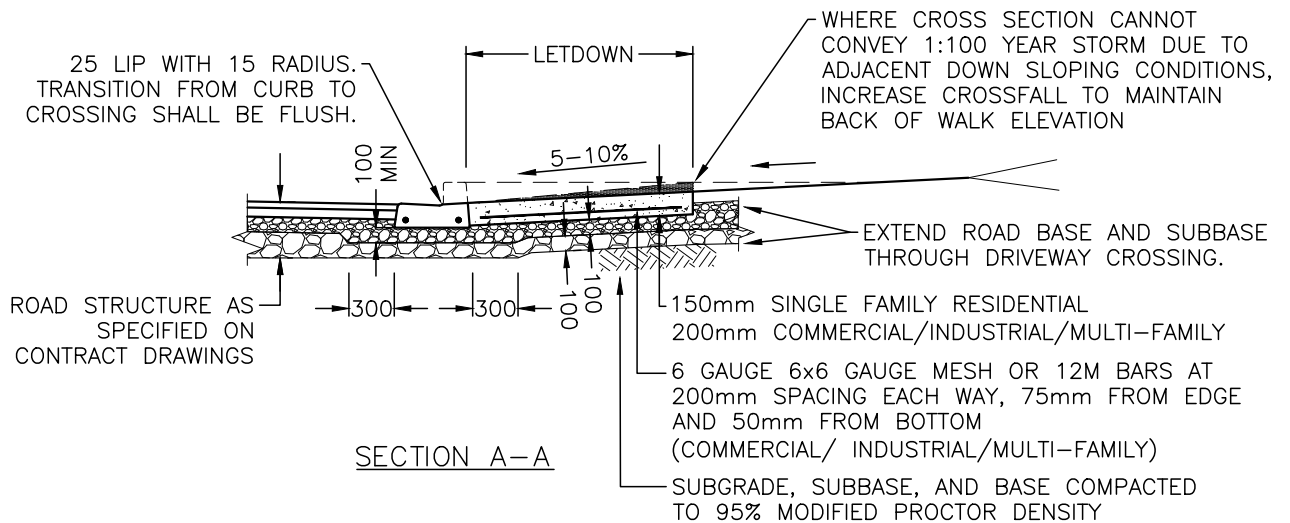

**NOTES:**

1. THIS STANDARD IS TO BE USED WHERE SIDEWALK SEPARATION FROM CURB & GUTTER IS NOT POSSIBLE. SEE DRAWING SS-C7a FOR PREFERRED OPTION.
2. DRIVEWAYS TO BE ORIENTATED AT 90° TO CURB, UNLESS OTHERWISE APPROVED.
3. ALL DIMENSIONS ARE IN MILLIMETRES UNLESS OTHERWISE NOTED.
4. REFER TO BYLAW 7900 FOR DRIVEWAY WIDTHS. UPON DEMONSTRATED NEED (TURN PATH ANALYSIS OR CAPACITY ANALYSIS), A VARIANCE TO THESE STANDARDS MAY BE CONSIDERED BY THE CITY ENGINEER.

**STANDARD  
DETAIL  
DRAWING**

DATE:  
OCT 31/22  
SCALE:  
NTS

**DRIVEWAY CROSSING FOR  
BARRIER CURBS**  
COMBINED SIDEWALK AND LETDOWN

DWG. NO.

**SS-C7b**

